

70-0773-WT & 70-0774-WT Rear Compartment Weatherstrip

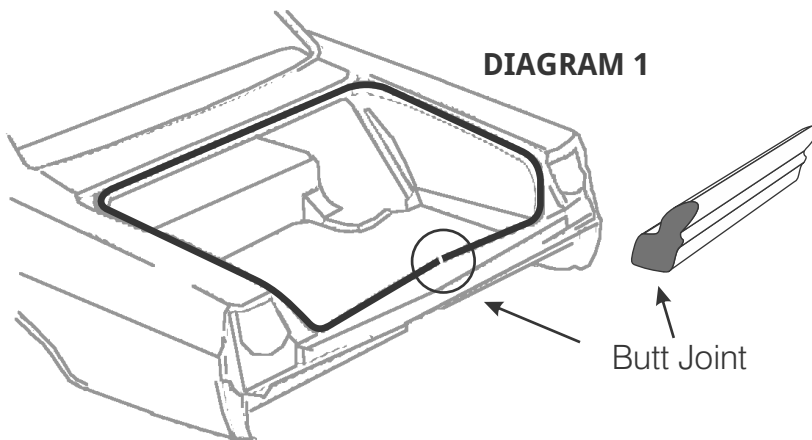

Our most popular trunk seal is now available with adhesive backing! The "Peel-N-Stick" design eliminates the use of messy glue and is much easier to install.

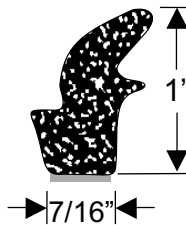

Lip Faces AWAY From Car.

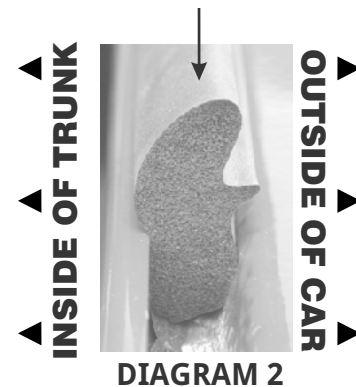

Instructions:

- 1. Examine New Seal-** Please examine the Peel-N-Stick trunk seal in this package to ensure it meets your expectations prior to installation. If this part has any defects, please contact us directly. We cannot accept returns of Peel-N-Stick parts that have been cut or altered.
- 2. Remove Old Seal-** Using a tuck tool or narrow plastic putty knife, peel one end of the old extrusion away from the trunk and scrape extrusion out of the track. Work your way around the trunk pulling up the old extrusion while simultaneously scraping as much of the old adhesive away as possible. Once old seal is out, any excess glue must be removed with adhesive remover until you have a clean metal track.
- 3. Clean & Prep Surface-** Before installing this part, the application surface must be clean and free of adhesive residue, grease, old seals or wax. Rubbing alcohol or the enclosed alcohol swabs are recommended as a means to ensure a properly prepared surface. Be sure to allow the alcohol to dry prior to installing the new Peel-N-Stick weatherstripping. The surface must be as clean and dry as possible to allow the Peel-N-Stick adhesive to function properly.
- 4. Installation-** When installing this part, please note that the lip faces away from the car as shown in diagram 2. Start at the lock end (as in diagram 1) and slowly peel back the red tape in short lengths as you press the weatherstripping onto the clean surface. Work your way around the perimeter and trim the excess weatherstripping (this trunk seal is slightly longer than needed to fit a variety of models) and butt the ends together as seen in diagram 1. Note: Once applied, damage to the weatherstripping or adhesive failure could occur if an attempt is made to remove and re-apply.

