

# Part# 20-3030-50 • Windshield Weatherstripping

## Fits 1952-1954 Ford & Mercury Cars

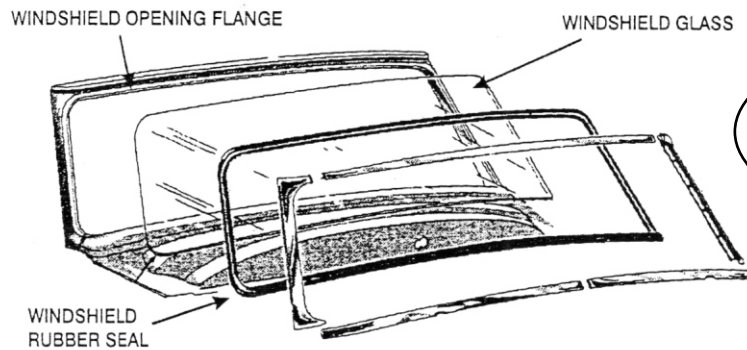

**NOTE:**  
It is necessary to use an auto glass sealer when installing the new rubber window seal to prevent leaking. Steele Rubber Products sells 3M brand Auto Bedding & Glazing Compound. Our part# is 96-8509-96

### Installing windshield rubber seal

1. Remove all old weather stripping and weather stripping sealer from the windshield opening flange. Clean the flange area thoroughly.
2. Trial fit the rubber seal onto the windshield. This allows you to orient how the seal should fit on the glass. Remove seal and prepare it for sealer application.
3. Apply a continuous bead of sealer to the windshield opening flange on the car.
4. Install the rubber seal onto the glass. If there are outside windshield moldings that are held into position by the rubber seal then they must be installed at this time.

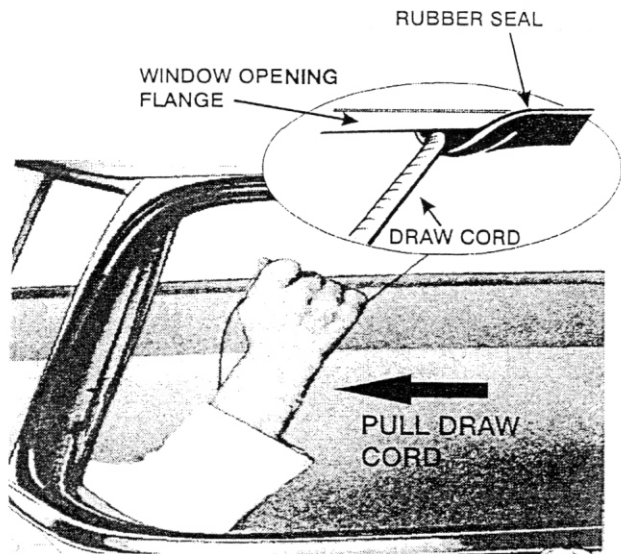



**HELPFUL TIPS**

Use masking tape to temporarily hold the seal onto the glass before installing the window. After the window has been installed the tape can be removed.

6. Position the glass assembly in the opening and have a helper apply pressure to the outside of the glass. From the inside, begin pulling the draw cord. This procedure allows the rubber seal to be pulled over the window opening flange area. Alternate from side to side when pulling the cord to keep the installation even. The draw cord operation will be completed at bottom center of the windshield. Pull the cord completely out of the rubber seal.
7. Once the windshield has been installed, tap the windshield around the perimeter with the palm of your hand to ensure that the rubber seal has been seated onto the window opening flange.

### Typical draw cord installation

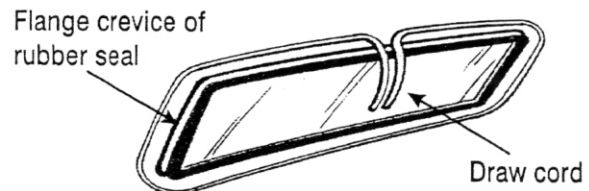

5. Apply a soap/water solution to the flange area of the rubber seal, then install a draw cord into the flange crevice of the rubber seal. Allow about 12 inches overlap at the top center

