

# Part# 20-1959-81 • Rear Window Weatherstripping

## Fits 1957-1958 Ford Sedans & Hardtops

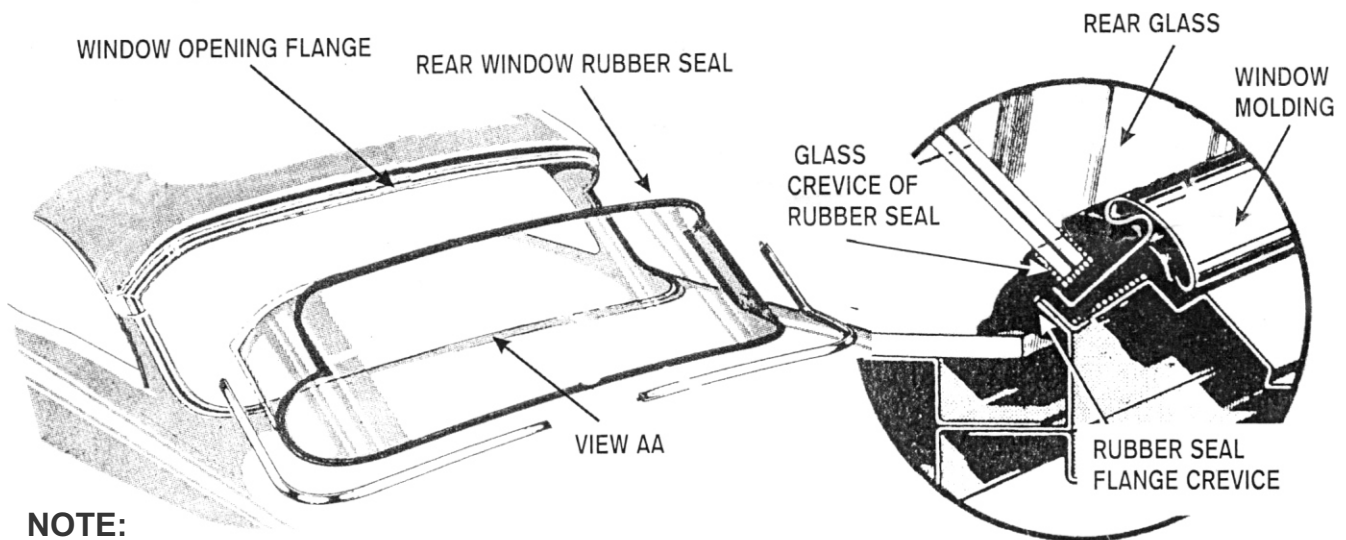

### NOTE:

It is necessary to use an auto glass sealer when installing the new rubber window seal to prevent leaking. Steele Rubber Products sells 3M brand Auto Bedding & Glazng Compound. Our part# is 96-8509-96

Window flange/rubber seal detail  
(VIEW AA)

### REINSTALLING REAR WINDOW RUBBER SEAL

1. Remove all old weather stripping and weather stripping sealer from the rear window opening flange.
2. Apply a continuous bead of sealer to the rear window opening flange. Apply a continuous bead of sealer into the glass crevice of the rubber seal then install the weather strip onto the glass.
3. Insert the window moldings into the rubber seal before installing the window into the car.
4. Apply a soap/water solution to the flange area of the weather strip, then install a draw cord into the flange crevice of the weather stripping. Allow about 12 inches overlap at the top center.
5. Position the glass assembly in the opening and have a helper apply pressure to the outside of the glass. From the inside, begin pulling the draw cord. This procedure allows the weather stripping to be pulled over the flange area. Alternate from side to side when pulling the cord to keep the installation even.
6. Install the top molding retaining clips (if used), then install the molding.
7. Install the lower molding end screws then install the side moldings (if used). Install any molding joint covers.

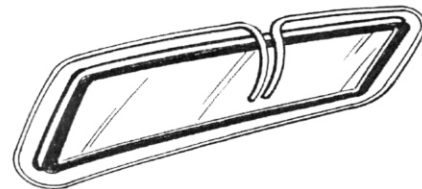

Install draw cord into flange crevice of rubber seal around entire window.

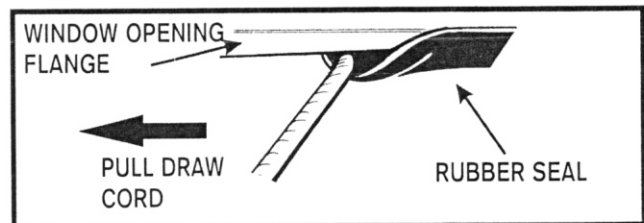

**HELPFUL TIPS** Assemble the rubber seal to the back glass and insert any window moldings that are held into position by the rubber seal before installing them into the car.

Masking tape can be used to temporarily hold the seal, glass, and lower moldings together while handling.

