

# 20-0790-42 • COWL LACING

1968-1979 FORD F-SERIES PICKUPS

1978-1979 FORD BRONCO



Quality Restoration Rubber Parts

## IMPORTANT

WHEN INSTALLING THIS COWL LACING ONTO  
1973-1977 FORD TRUCKS IT MUST FIRST BE SHORTENED.

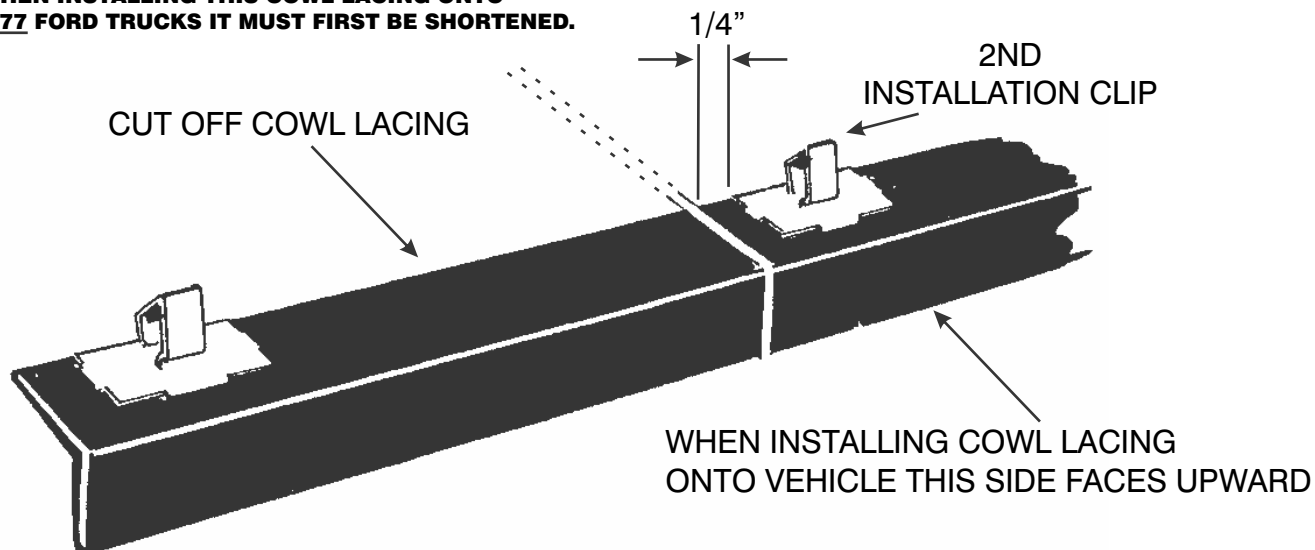

When installing this cowl lacing onto 1973-1977 model trucks, the cowl lacing must be cut shorter in order for the snap-in clips to properly align with the holes on the firewall.

1. REFER TO DRAWING TO DETERMINE WHERE TO CUT LACING.

With a sharp knife, cut the passenger side end of the cowl lacing off 1/4" to the left of the 2ND INSTALLATION CLIP. (See illustration for reference)

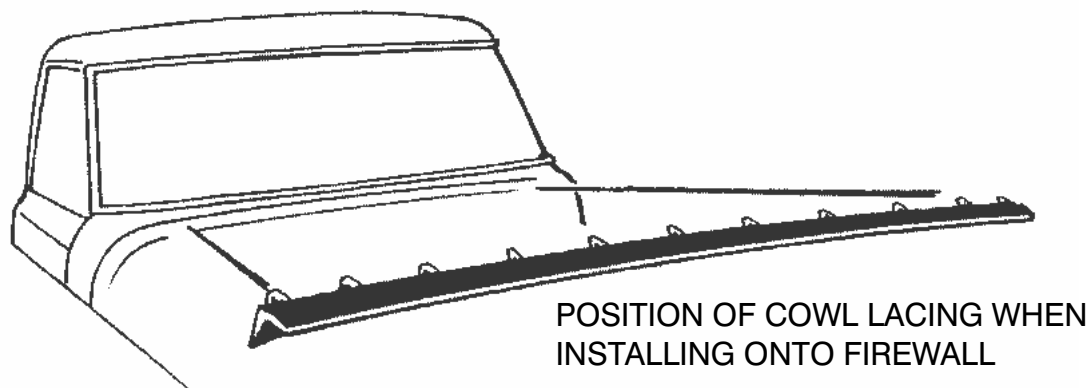

2. Making sure that the horizontal flap of the cowl lacing is facing upward, Install the cowl lacing by snapping the retaining clips into the appropriate holes on the firewall.

[WWW.STEELERUBBER.COM](http://WWW.STEELERUBBER.COM)

